

# Conventional Intrinsically Safe Sounder



### Technical Data

Maximum sound output at one metre	100dB(A)
Supply voltage	6-28 V dc
Current (tone dependent)	25 mA typical
Rating	Continuous
Number of tones	49
Operating temperature	-40°C to +60°C
IP Rating	designed to IP65
Standards & approvals	ATEX, IECEx
Weight	0.35 kg
Cable entries	2
Construction	High-impact flame retardant ABS

### Product Overview

Product	I.S. Conventional Sounder
Part No.	29600-379

### Approvals



### Product Information

The Conventional Intrinsically Safe (I.S.) Sounder provides an audible warning signal in hazardous areas.

With three alarm stages and a low current consumption the Conventional I.S. Sounder is ideal for both fire and process control applications.

The sounder needs to be used with a galvanic isolator as specified by the system certificates.

- ATEX certified
- IECEx certified
- Suitable for Group I mining applications

### Conventional I.S. Sounder dimensions

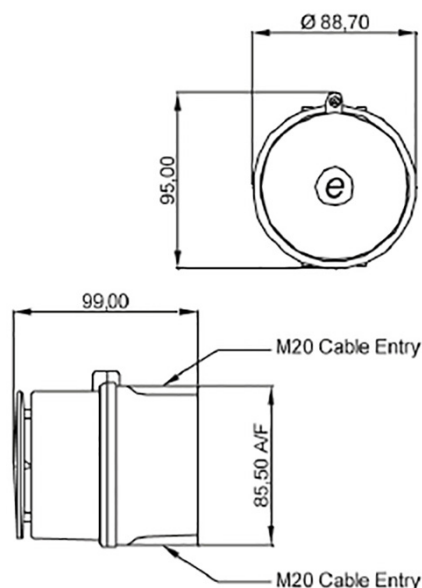

Suitable for the applications that follow:

- Industrial
- Railway/Marine
- Hazardous areas
- Public warning

**This page has intentionally been left blank**