



Conventional Marine Outdoor Manual Call Point Installation Guide

General

The Conventional Marine Outdoor Manual Call Point-Red, part number 55100-022 MAR, model number WCP2A-R470SF-A071-02 is a 'type A' call point and is suitable for outdoor use.

Installation

1. Fit the backbox to a flat surface using the three fixing holes and screws provided. The cable entry holes should be in the vertical plane. The backbox can be mounted with either the single or double entry holes at the top (Fig 1).

Note: Cable entry from the bottom of the call point is recommended if there is a possibility of moisture condensing within the conduit or cables.

2. Remove terminal block from the PCB. Run the cables into the backbox and connect them to the terminal block as shown in Fig 2. Ensure that functional earth/screen continuity is maintained. Screens should be connected to the terminal in the backbox.
3. Reconnect the terminal block to the PCB and ensure that the O-ring is correctly seated in its channel. Place the cover squarely over the backbox and carefully push the cover until the locating clips have engaged, use the 4 fixing screws to lock the cover in place. **Do not use excessive force, do not over tighten screws.**
4. To remove the cover, undo and remove the four cover fixing screws. The four retaining clips also need to be released. To do this, place a flat bladed screwdriver into the slot between the cover and backbox and gently twist until the clip disengages (Fig 3). Repeat this for the three remaining clips and pull the cover away from the backbox.

Wiring Details

To maintain the integrity of the enclosure it is essential that suitable IP67 cable glands be used.

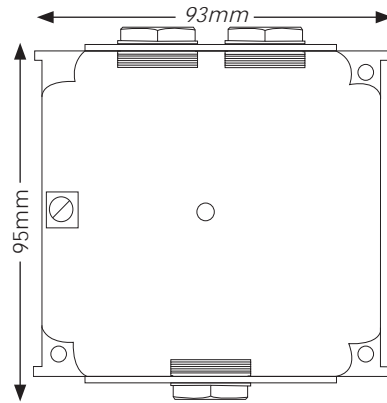

Fig 1 Backbox

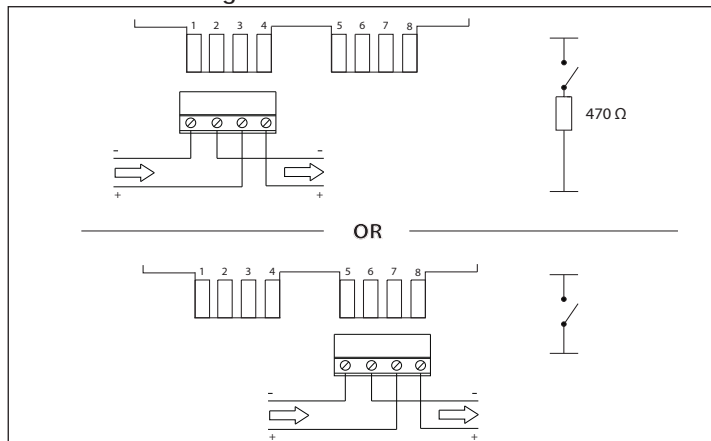

Fig 2 Terminal block connections

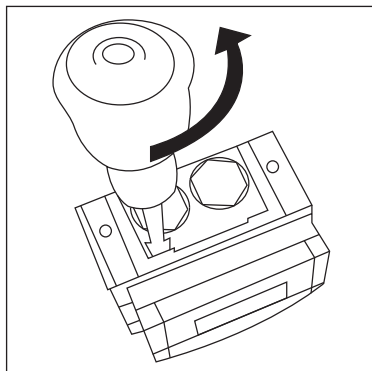

Fig 3 Cover removal

Technical Data

Maximum Voltage	30VDC
Maximum Switching Current	2A
Alarm Resistor	470 Ω / 1W
IP rating	IP67
Operating Temperature	-25°C to 70°C

Commissioning

The installation must conform to BS5839-1 (or applicable local codes).

Ensure that the deformable element is fitted to each call point before testing. Use the test key provided to check the operation of each device.

Troubleshooting

Before investigating individual units for faults, it is important to check that the system wiring is fault free.

Many fault conditions are the result of simple wiring errors. Check all connections to the unit.

General Fault Finding

Problem	Possible Cause
Control panel reports zone fault	Incorrect zone wiring Detector removed
Control panel reports alarm	EOL device missing or incorrectly fitted MCP not reset Test key not removed
MCP does not activate alarm	Incorrect EOL device Incorrect wiring Incompatible control panel

Routine testing

Insert the test key into the hole at the bottom of the call point and push home. Observe routine test requirements as specified in the applicable local codes.

Resetting

After testing, reset the call point by removing the test key and pushing up the front cover until it clicks home.

Earthing

An earthing plate is provided for continuity of metal conduits. This must be placed behind the back box prior to fixing the box to the wall. Fit the three M20 nylon washers between the earthing plate and the backbox before fitting cable glands, conduit or blanking plugs.

Important Information

The use of lubricants, cleaning solvents or petroleum based products should be avoided. The O-ring should be replaced when refitting or replacing the waterproof cover.

Transparent hinged cover

To provide additional protection against accidental operation, a transparent hinged cover, part no 26729-152, is available.

To prevent against malicious activations of call points, locking tags are also available, part no. 26729-179.

Please note that the call point does not conform to EN54-11:2001 when the hinged cover is **secured with the locking tag**.

For further information, please refer to PP2419.