



Stainless Steel Intelligent IR3 Flame Detector Installation & Maintenance Guide

General

The Stainless Steel Intelligent IR3 Flame Detector, part no 55000-034MAR, is designed for use where open flaming fires may be expected. It is sensitive to low-frequency, flickering infra-red radiation emitted by flames during combustion. False alarms due to such factors as flickering sunlight are avoided by a combination of filters and signal processing techniques.

Response to flames

In quiescent condition, ie, in the absence of a flame, the detector returns an analogue value of 25. When a flame is visible, the detector signals an alarm by increasing the analogue value returned to 55, usually within 1.5 seconds. The analogue value may continue to rise until it reaches a pre-set maximum of 64.

In the alarm state the Stainless Steel Intelligent IR3 Flame Detector latches for 20 seconds, with the analogue value decreasing to 25 once the flame is no longer detected.

Electrical considerations

The Stainless Steel Intelligent IR3 Flame Detector is loop powered and needs no external power supply. It is connected to a control panel using either the XP95 or Discovery protocol. A remote LED alarm indicator may be connected to the flame detector.

Sensor window contamination

It is important to keep the sensor window clean and checks should be carried out at regular intervals (determined locally according to the type and degree of contamination encountered) to ensure optimal performance of the flame detector. Although flames can be detected when the window is contaminated, there may be a reduction of sensitivity as shown in the table overleaf.

It is recommended that the flame detector be disabled when the window is being cleaned.

Contaminant	Typical percentage of normal response
Water spray	75
Steam	75
Smoke	75
Oil film	86
Salt water film	86
Dry salt deposits	86

Table 1 *Sensor window contamination*

Applications for flame detectors

Flame detectors are used when detection is required to be unaffected by convection currents, draughts or wind; tolerant of fumes, vapours, steam, dust and mist; responsive to a flame more than 25m away and fast reacting.

Typical applications examples are ships' engine rooms and marine applications where there is a requirement for a triple IR Flame Detector that is resistant to corrosion from salt water. See Apollo PIN Sheet PP2409 for the full range applications of flame detectors.

Quantities required and positioning of detectors

The number of detectors required and their positioning depends on:

- the anticipated size of the flame
- the distance of the flame from the detector and
- the angle of view of the flame detector

The Stainless Steel Intelligent IR3 Flame Detector is designed to operate to Class 1 performance as defined in EN54: Part 10. The detector will therefore, detect a yellow flickering flame of approximately 0.1m² or a clear flame of 0.25m² at 25m.

In fact, the flame detector will detect fires at distances of up to 40 metres, but the flame size at such distances needs to be proportionally greater in order to be sure of reliable detection. Thus the yellow flickering flame that can be detected at 25m, provided that its size is not less than 0.1m², will have to be 0.4m² in order to be detected at 40 metres. In a rectangular room the distance from the flame detector to the fire is calculated by the formula:

$$\sqrt{L^2 + W^2 + H^2}$$

In the example shown in Fig 1 the room in which the flame detector is to be installed measures 20m x 10m x 5m; the distance from the detector to the flame will therefore be:

$$\begin{aligned} &\sqrt{20^2 + 10^2 + 5^2} \\ &= 22.9\text{m} \end{aligned}$$

Technical Data

Supply voltage	14–28V DC
Quiescent current	2.2mA
Alarm current	4.2mA
Switch-on surge current	30mA (peak) for 15mS
Power-up time	4 seconds
Remote LED voltage	0–28V DC
Remote LED current	limited to 2mA
Fire alarm threshold	Analogue value 55 returned after 10Hz flame flicker for 1.5 seconds
Operating range	25m for 0.1m ² n-heptane fire 35m for 0.2m ² n-heptane fire 45m for 0.4m ² n-heptane fire
Operating temperature	–10°C to +55°C
Storage temperature	–20°C to +65°C
Relative humidity	95% (no condensation)
IP rating	65
Housing material	Stainless Steel (316 grade)
Size and weight	142 x 108 x 82mm, 2 kg
Cable gland entries	2 x 20mm

For further technical information refer to PP2424.

Additional Equipment

Flame detector weathershield part no 29600-206

Flame sensor test unit part no 29600-226

Functional testing

When polled by a compatible panel or test set, the flame detector, in quiescent condition, should return an analogue value of 25 and input bits set to '0'.

If output bit 2 is set to logic 1 on two or more consecutive pollings, the red 'FIRE' LED on the flame detector will illuminate.

If output bit 1 is set to 1 on two or more consecutive pollings the flame detector will perform a self test. It does this by causing internal LEDs to flicker in the field of view of the flame detector, thus simulating the behaviour of flames.

If output bit 0 is set to 1 on two or more consecutive pollings the flame detector will switch on a remote LED.

Finally, provided it is safe to do so, carry out a flame test using a flickering flame source, such as a portable bunsen burner. A still, non-flickering flame will not produce a response from the detector.

Maintenance Guide

The flame detector is designed to give years of trouble-free operation with minimal attention. However the periodic maintenance steps listed below are essential to maintain reliable fire protection.

1. Inform all appropriate personnel of intention to work on the flame detector.
2. Disable any automatic systems that may be activated by the flame detector if not required as part of the maintenance check.

Alarms	Extinguishers	Control
Audio/Visual	Gas systems	Plant stops
Auto diallers	Water sprays	Dampers/doors

3. Check that the flame detector's control panel is functioning correctly and shows no faults.

4. Inspect the detector viewing window for any build-up of dust or other contaminants on the optical surface. If necessary clean the optical surface with a cotton wipe wet with commercial liquid glass cleaner. Rinse with clean water and dry with a clean cloth.

The detector specification for performance is with a clean optical sensor window. Contaminants like dust, oil and paint will reduce sensitivity.

5. Ensure the detector still has a clear line of sight to the area it is protecting and no obstacles obstruct its view.

6. Check that the detector is securely fitted.

7. Visually check the exterior of the detector for any mechanical damage.

8. Test the operation of the detector with either a portable flame sensor test unit or if practical a flickering yellow flame.

9. Reinstate any automatic system disabled during maintenance.

10. Inform all appropriate personnel on completion of the maintenance work and if necessary record this work.

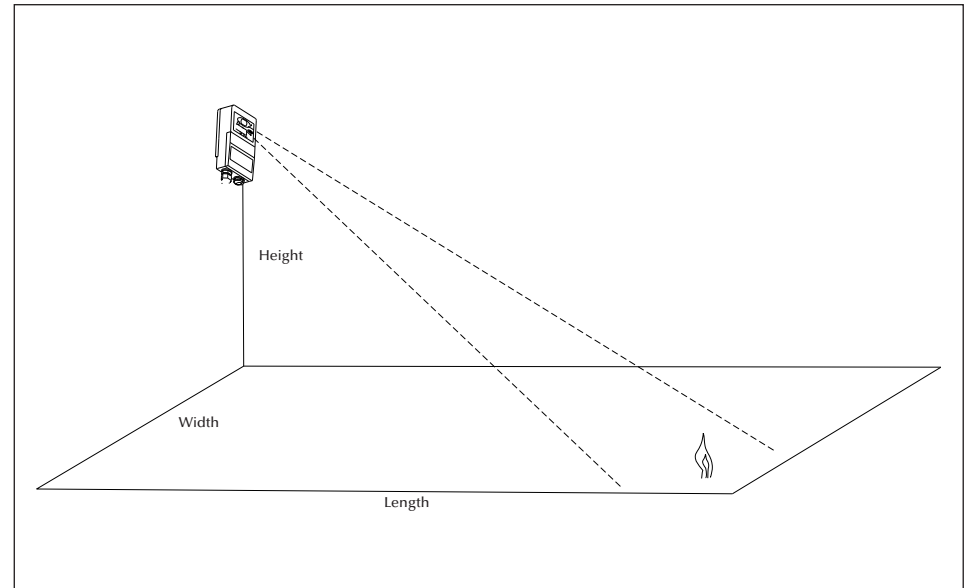

Fig 1 Calculation of distance from detector to flame

The flame detector has an angle of view of approximately 90°, as shown in the diagram below.

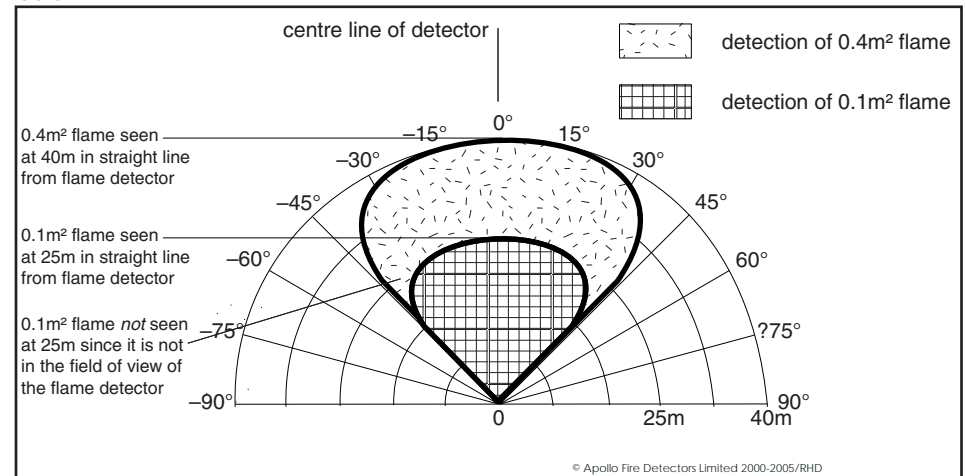

Fig 2 Angle of view of Stainless Steel Flame Detector

The flame detector should be positioned at the perimeter of the room, pointing directly at the area of the anticipated flame or at the centre of the area to be protected. If the detector cannot 'see' the whole of the area to be protected, one or more additional detectors may be required.

The flame detector is not affected by normal light sources but should be positioned so that sunlight does not fall directly onto the viewing window.

Loop design

The Stainless Steel Intelligent IR3 Flame Detector is powered from the loop; it draws 2.2mA in quiescent state and 4.2mA in alarm. In order to determine the number of flame detectors that can be connected to a given loop, please refer to the Loop Calculation program, which can be downloaded from the Apollo website or requested from Apollo's Technical Sales department as a CD.

Address Setting

Before installing the flame detector it is necessary to set the address using the DIL switch, which is accessed by removing the front cover, using a 5mm hexagonal key. 7 segments of the switch are set to 0 or 1, using a small screwdriver or similar tool.

A complete list of address settings is shown in the following table.

DIL switch setting 1234567	DIL switch setting 1234567	DIL switch setting 1234567	DIL switch setting 1234567	DIL switch setting 1234567	DIL switch setting 1234567	DIL switch setting 1234567	DIL switch setting 1234567	DIL switch setting 1234567	DIL switch setting 1234567
1	1000000	11	1101000	21	1010100	31	1111100	41	1001010
2	0100000	12	0011000	22	0110100	32	0000010	42	0101010
3	1100000	13	1011000	23	1110100	33	1000010	43	1101010
4	0010000	14	0111000	24	0001100	34	0100010	44	0011010
5	1010000	15	1111000	25	1001100	35	1100010	45	1011010
6	0110000	16	0000100	26	0101100	36	0010010	46	0111010
7	1110000	17	1000100	27	1101100	37	1010010	47	1111010
8	0001000	18	0100100	28	0011100	38	0110010	48	0000110
9	1001000	19	1100100	29	1011100	39	1110010	49	1000110
10	0101000	20	0010100	30	0111100	40	0001010	50	0100110
51	1100110	61	1011110	71	1110001	81	1000101	91	1101101
52	0010110	62	0111110	72	0001001	82	0100101	92	0011101
53	1010110	63	1111110	73	1001001	83	1100101	93	1011101
54	0110110	64	0000001	74	0101001	84	0010101	94	0111101
55	1110110	65	1000001	75	1101001	85	1010101	95	1111101
56	0001110	66	0100001	76	0011001	86	0110101	96	0000011
57	1001110	67	1100001	77	1011001	87	1110101	97	1000011
58	0101110	68	0010001	78	0111001	88	0001101	98	0100011
59	1101110	69	1010001	79	1111001	89	1001101	99	1100011
60	0011110	70	0110001	80	0000101	90	0101101	100	0010011
101	1010011	106	0101011	111	1111011	116	0010111	121	1001111
102	0110011	107	1101011	112	0000111	117	1010111	122	0101111
103	1110011	108	0011011	113	1000111	118	0110111	123	1101111
104	0001011	109	1011011	114	0100111	119	1110111	124	0011111
105	1001011	110	0111011	115	1100111	120	0001111	125	1011111
								126	0111111

Table 2 DIL switch address settings

We recommend that the address be set before the flame detector is mounted on the wall.

Sensitivity setting

The eighth segment of the DIL switch referred to in the previous section is used to set the sensitivity of the flame detector to class 1 or class 3. For most practical purposes the switch should be set to class 1, the sensitivity required to detect flames as described in the section 'Quantities required and positioning of detectors'.

In exceptional cases the flame detector may be set to class 3 operation in order to avoid nuisance alarms being caused by radiation sources that are close to the detector and can not be moved.

To set the DIL switch to class 1, switch to position '1'. To set to class 3, switch to position '0'.

Installation

The flame detector can be mounted on an adjustable mounting bracket, part no 29600-203, which is bolted to the detector rear.

The detector can be mounted without a bracket and used for horizontal viewing, eg, along corridors or along the length of industrial processes or vertical viewing inside fume cupboards or over hoppers. It has two fixing holes with 1/4" threads at 76.2mm centres.

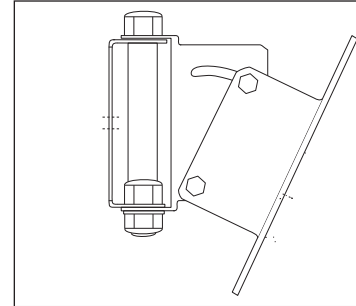

Flame detectors should be fitted to solid walls or to rigid constructions that do not move and are not subject to vibration.

Fig 3 Optional bracket, part no 29600-203

Wiring

The flame detector has five connections: L2+, L1-, +Remote, -Remote and functional earth/screen. The connections are accessed by removing the front plate of the flame detector. The cable is passed through the gland at the base of the detector. See Fig 4 for connection diagram.

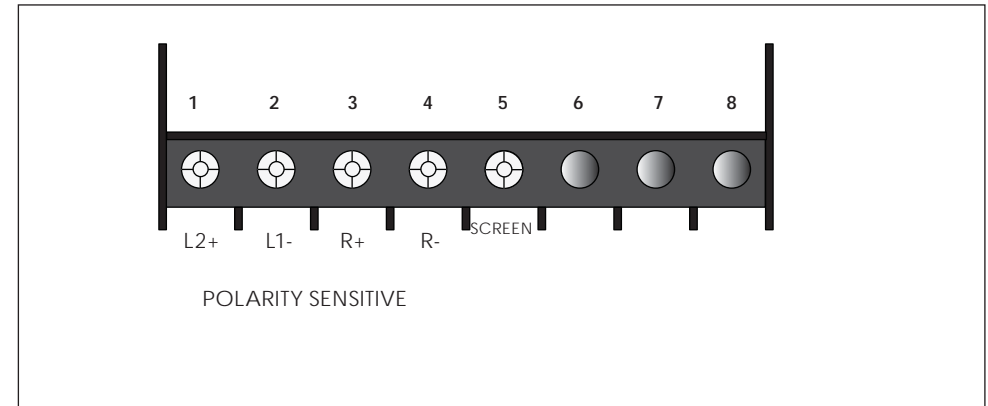

Fig 4 Flame detector wiring connections

Terminal Descriptions

1	L2+	+Line IN and OUT	Terminals 6 to 8 are not used
2	L1-	-Line IN and OUT	
3	R+	+Remote LED	
4	R-	-Remote LED	
5	SCREEN	Functional Earth/Screen (Isolated)	