

**Technical Data**

Supply voltage	14–30V DC (polarity sensitive)
Quiescent current	8mA (default), 4 & 3mA (selectable)
Alarm current	28mA (default), 20, 14 & 9mA (selectable)
Relay contact voltage	50Vdc. Max
Relay contact current	1.0Amp. Max.
Relay contact power	30W Max.
Power-up time	2 seconds
Test signal voltage	14-30V DC
Operating range – Class 1 setting	25m for 0.1m <sup>2</sup> n-heptane (see EN54-10)
Operating range – Class 3 setting	12m for 0.1m <sup>2</sup> n-heptane (see EN54-10)
Field of view/angle of reception	90° Cone
Operating temperature	–10°C to +55°C (no condensation or icing)
Storage temperature	–20°C to +65°C
Relative humidity	95% (no condensation)
IP rating	65
Housing material	Die cast zinc alloy (ZA 12)
Housing colour	Blue
Dimensions	142 x 108 x 82mm
Weight	2kg
Cable gland entries	2 x 20mm



## Conventional UV/IR2 Flame Detector Installation & Maintenance Guide

**General**

The Conventional Ultraviolet and Dual Infra-red (UV/IR2) Flame Detector, part no 55000-064, is designed for use where open flaming fires may be expected. It is sensitive to low-frequency, flickering infra-red radiation emitted by flames during combustion. False alarms due to such factors as flickering sunlight are minimised by a combination of optical filters and signal processing techniques.

**Response to Flames**

The detector is normally configured to latch into an alarm state when a flame is detected, increasing the current drawn from the supply. The supply to the detector has to be broken in order to reset the detector. Volt free contacts from two internal relays RL1 (Fire) and RL2 (Fault or pre-alarm) are available to signalling the detectors status back to the control equipment.

The configuration DIL switch within the detector can be set to place the detector into a non-latching mode. The detector can then also produce a proportional analogue current alarm signals i.e. 8-28mA or 4-20mA. In non-latching mode the detector only produces an alarm signal when a flame is in view, resetting itself to normal when the flame has gone.

**Electrical Considerations**

The flame detector can be connected in many different electrical configurations depending on the application. The detector requires a 24Vdc (14Vmin. to 30Vmax.) supply to operate. The detector can be connected as a two-wire loop powered device increasing its supply current to signal that a flame has been detected.

The supply connections to the detector are polarity sensitive.

Also available are volt free contacts from two internal relays RL1 (Fire) and RL2 (Fault or pre-alarm). Using the relay contacts connected in a four-wire configuration the detector status can be signalled back to control equipment.

Removing the detector front cover provides access to the detector terminals and configuration DIL switch. See Fig 5.

**Approval and Regulatory Information**

0832 010an/10 14 CD0006/FLAME EN54-10 Flame Detectors - Point Detectors

**Additional Equipment**

Stainless Steel Adjustable Mounting	part no 29600-203
Stainless Steel Weather Shield	part no 29600-206
Portable Flame Detector Test unit	part no 29600-226

*Information in this guide is given in good faith, but the manufacturer cannot be held responsible for any omissions or errors. The company reserves the right to change the specifications of products at any time and without prior notice.*

Apollo Fire Detectors Limited,  
36 Brookside Road, Havant, Hants, PO9 1JR, UK  
Tel +44 (0) 23 9249 2412 Fax +44 (0) 23 9249 2754  
www.apollo-fire.co.uk

### Sensor Window Contamination

It is important to keep the sensor window clean and checks should be carried out at regular intervals—determined locally according to the type and degree of contamination encountered—to ensure optimal performance of the flame detector. Although flames can be detected when the window is contaminated, there may be a reduction of sensitivity as shown in the table overleaf.

It is recommended that the flame detector be disabled when the window is being cleaned.

### Applications for UV/IR2 Flame Detectors

Flame detectors are used when detection is required to be unaffected by convection currents, draughts or wind; tolerant of fumes, vapours, responsive to a flame more than 25m away and fast reacting.

Typical applications examples are:

- aircraft hangars
- engine rooms
- engine test facilities
- fuel storage and handling
- generators
- high voltage equipment
- nuclear industry
- petro-chemicals
- power plants
- printing
- storage tanks

Applications and locations to avoid:

- prolonged ambient temperatures above 55°C
- sunlight falling directly onto IR2 optics
- exposure to severe rain and ice
- flicking or moving hot objects
- flood or spot lighting falling directly on IR optics
- large amounts of flickering reflections
- obstructions to field of view

### Functional Testing

When 24Vdc power is applied to the detector the green supply on indicator LED will illuminate. The fault relay RL2, if selected with the DIL switch, will energise and the contact between terminals 7 and 8 will close. Testing the operation of the detector can be achieved in three ways, providing it is safe to do so:

- A portable flame detector tester unit
- Apply 24Vdc to terminals 3 and 4 to perform a self test from internal optical test sources
- A real flame from a portable flickering yellow bunsen flame. A still, non-flickering flame will not produce a response from the detector

### Maintenance Guide

The flame detector is designed to give years of trouble-free operation with minimal attention. However the periodic maintenance steps listed below are essential to maintain reliable fire protection.

1. Inform all appropriate personnel of intention to work on the flame detector.
2. Disable any automatic systems that may be activated by the flame detector if not required as part of the maintenance check.

Alarms	Extinguishers	Control
Audio/visual	Gas systems	Plant stops
Auto dialers	Water sprays	Dampers/doors

3. Check that the flame detector's control panel is functioning correctly and shows no faults.
4. Inspect the detector viewing window for any build-up of dust or other contaminants on the optical surface. If necessary clean the optical surface with a cotton wipe wet with commercial liquid glass cleaner. Rinse with clean water and dry with a clean cloth.

The detector specification for performance is with a clean optical sensor window. Contaminants like dust, oil and paint will reduce sensitivity.

5. Ensure the detector still has a clear line of sight of the area it is protecting and no obstacles obstruct its view.
6. Check that the detector is securely fitted.
7. Visually check the exterior of the detector for any mechanical or corrosive damage.
8. Test the operation of the detector with either a portable flame sensor test unit or if practical a flickering yellow flame.
9. Reinstate any automatic system disabled during maintenance.
10. Inform all appropriate personnel on completion of the maintenance work and if necessary record this work.

### Sensitivity Setting

The eighth segment of the DIL switch is used to set the sensitivity of the flame detector to class 1 or class 3. For most practical purposes the switch should be set to class 1 (default setting), the sensitivity required to detect flames as described in the section 'Quantities required and positioning of detectors'.

In exceptional cases the flame detector may be set to class 3 operation in order to avoid nuisance alarms being caused by radiation sources that are close to the detector and cannot be moved.

To set the DIL switch to class 1, switch to position '1'. To set to class 3, switch to position '0'. The DIL switch is located above the detector terminals.

### Installation

The flame detector is connected to conventional control panel and would normally be wall or ceiling mounted preferably on an adjustable bracket to adjust the angle of view, part no 29600-203.

The standard mounting is used for horizontal viewing, eg, along corridors or along the length of industrial processes or vertical viewing inside fume cupboards or over hoppers.

Flame detectors should be fitted to solid walls or rigid constructions that do not move and are not subject to vibration.

### Wiring

The flame detector has eight connections: [1]+IN, [2]-IN, [3]+R, [4]-R, [5]/[6] RL1 and [7]/[8] RL2. The connections are accessed by removing the detector front cover. See Fig 5 for connection diagram.

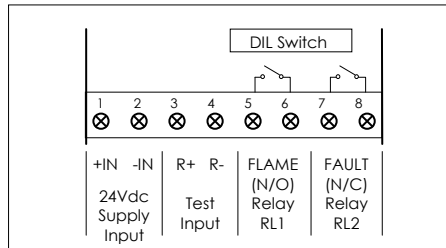

Fig 5 Flame detector connections under front cover

### Terminal Descriptions

1	+IN	+ 24Vdc Supply Input
2	-IN	- 24Vdc Supply Input (Internally connected to terminal 4)
3	R+	+ Test Input
4	R-	- Test Input (Internally connected to terminal 2)
5	RL1	Flame Relay, normally open (N/O)
6		
7	RL2	Fault Relay, normally closed (N/C) when powered.
8		

### Quantities Required and Positioning of Detectors

The number of detectors required and their positioning depends on:

- the anticipated size of the flame
- the distance of the flame from the detector
- the angle of view of the flame detector

The flame detector is designed to operate to Class 1 performance as defined in EN54:Part 10. The detector will, therefore, detect a yellow flickering flame of approximately 0.1m<sup>2</sup> or a clear flame of 0.25m<sup>2</sup> at 25m.

In fact, the flame detector will detect fires at distances of up to 40 metres, but the flame size at such distances needs to be proportionally greater in order to be sure of reliable detection. Thus the yellow flickering flame that can be detected at 25m, provided that its size is not less than 0.1m<sup>2</sup>, will have to be 0.4m<sup>2</sup> in order to be detected at 40 metres. In a rectangular room the distance from the flame detector to the fire is calculated by the formula:

$$\sqrt{L^2 + W^2 + H^2}$$

In the example shown in Fig 1 the room in which the flame detector is to be installed measures 20m x 10m x 5m, the distance from the detector to the flame will therefore be:

$$\sqrt{20^2 + 10^2 + 5^2}$$

$$= 22.9\text{m}$$

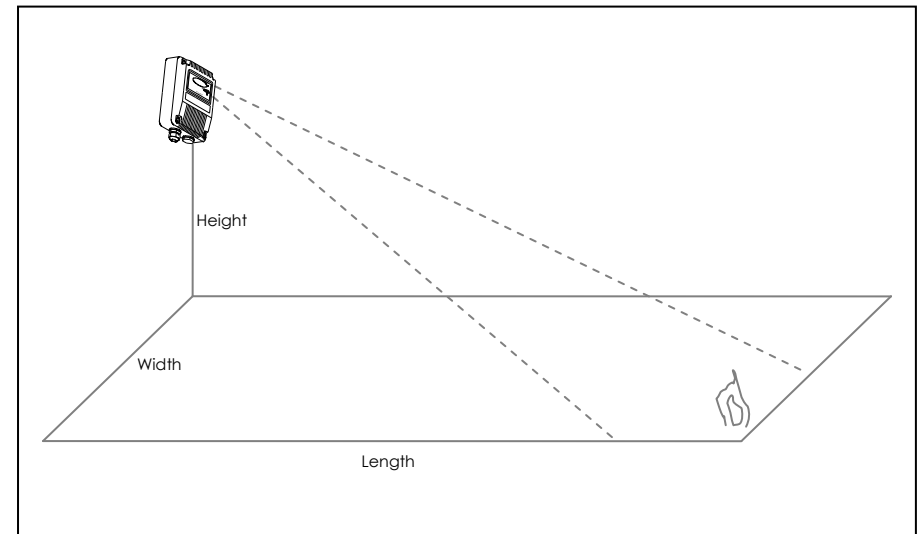

Fig 1 Calculation of distance from detector to flame

The flame detector has an angle of view of approximately 90°, as shown in the diagram below.

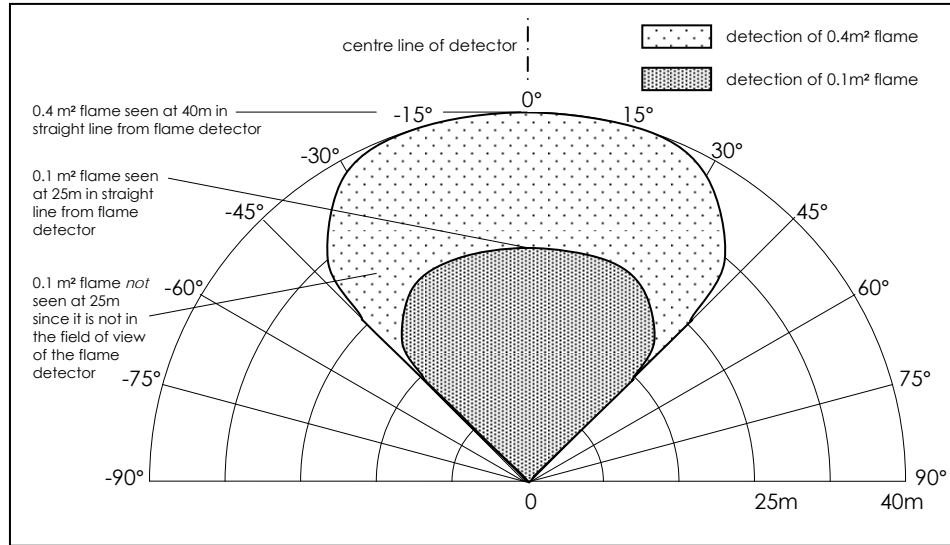

Fig 2 Angle of view of UV/IR2 Flame Detector

To meet the requirements of EN54:10 clause 5.4, were the ratio of the response points  $D_{max}:D_{min}$  should not exceed 1.41. The horizontal and vertical viewing angles  $\alpha_{max}$  should not exceed  $\pm 30^\circ$ .

The flame detector should be positioned at the perimeter of the room, pointing directly at the area of the anticipated flame or at the centre of the area to be protected. If the detector cannot 'see' the whole of the area to be protected, one or more additional detectors may be required.

The flame detector is not affected by normal light sources but should be positioned so that sunlight does not fall directly onto the viewing window.

**Selectable Detector Functions (DIL Switch Settings)**

	DIL Switch Setting	
	1	2
<b>Relay RL2 Function:</b>		
RL2 off (No fault relay) – For lowest detector current consumption.	0	0
RL2 off, or UV pre-alarm or electrical spark detection.	1	0
RL2 energised on IR pre-alarm	0	1
RL2 detector fault relay (Energised if detector powered and no faults)	1	~ 1
<b>Detector Supply Current (Detector Status):</b>	<b>3</b>	<b>4</b>
Low current mode, 3 to 9mA (RL1 Only), 8 to 14mA (RL1 & RL2)	0	0
Two-wire current signalling only. No relays operating. 4 to 20mA	1	0
Two-wire or four-wire applications. Current signalling 8 to 20mA and both relays operating.	0	1
Two-wire or four-wire applications. Current signalling 8 to 28mA and both relays operating.	1	~ 1
<b>Output Mode:</b>	<b>5</b>	
(-) Proportional analogue supply current.	Non-latching fire alarm signalling. (-)	
(/) Step change, supply current.	Latching fire alarm signalling. (/)	
<b>Response Time:</b>	<b>6</b>	<b>7</b>
Slowest ≈ 8s	0	0
Medium ≈ 4s	1	~ 0
Fast ≈ 2s	0	1
Very Fast ≈ 1s	1	1
<b>Sensitivity: See EN54-10</b>	<b>8</b>	
Low Class 3	0	
High Class 1	~ 1	

Factory setting ~

Table 1 DIL switch settings

**Connection Information**

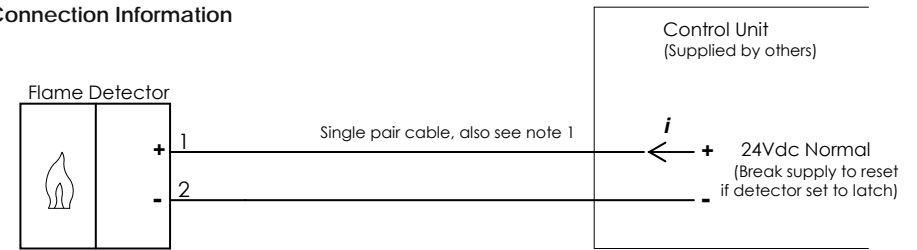
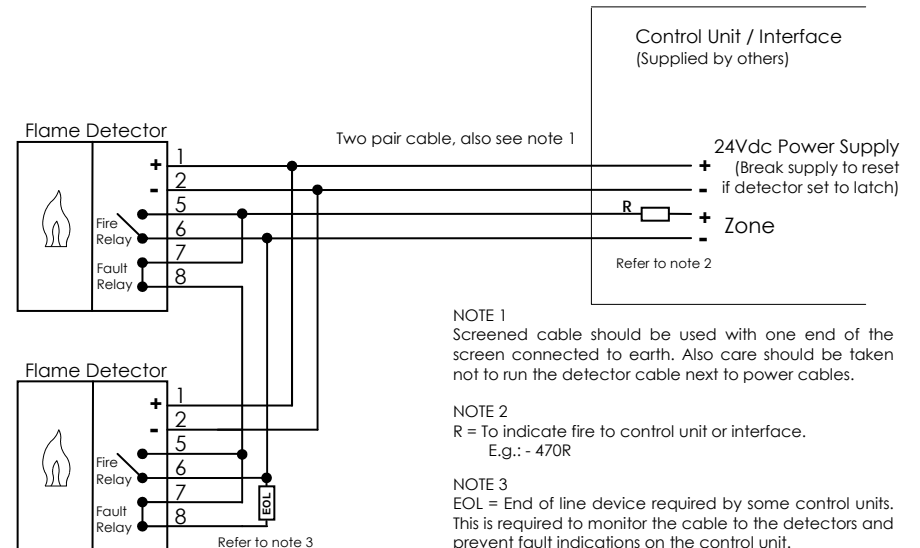

Fig 3 2 Wire basic single detector connection diagram

The simplest method of connecting the flame detector is in a 2-wire configuration as shown in Fig 3. With a 24Vdc supply the current ( $i$ ) drawn by a detector can be monitored to determine the detector status. The DIL switches within the detector can be set to produce different current values ( $i$ ) to suit control systems. See table 2

Detector Supply Current	Normal Quiescent Current	Alarm (Fire) Current	DIL Switch Setting				Comment
			1	2	3	4	
3mA	9mA		0	0	0	0	Lowest power configuration, RL1 only
4mA	20mA		0	0	1	0	For 4-20mA systems, no relays
8mA	14mA		1	1	0	0	Lowest power configuration & relays
8mA	20mA		1	1	0	1	For 4-20mA system & relays
8mA	28mA		1	1	1	1	Fire control panels (Default setting)

Table 2 Detector supply current signalling options



NOTE 1  
Screened cable should be used with one end of the screen connected to earth. Also care should be taken not to run the detector cable next to power cables.

NOTE 2  
R = To indicate fire to control unit or interface.  
E.g.: - 470R

NOTE 3  
EOL = End of line device required by some control units. This is required to monitor the cable to the detectors and prevent fault indications on the control unit.

Fig 4 4 Wire connection diagram

The circuit shown in fig 4 enables the flame detectors to interface with most type of fire alarm control systems. The fire relay RL1 is used to switch the required alarm load 'R' to generate a fire alarm signal. An end of line device 'EOL' mounted in the last detector provides the system with the ability to monitor the detector fault relay RL2 and the integrity of the interconnecting cables.