

Note

1. All circuits are power limited except for relay contacts. If the relay contacts are connected to a non power limited source, remove the lower portion of the power limited label along the kiss cut. Use only limited energy cable types FPL, FPLR or FPLP on power limited circuits.

Specifications

Part No	55000-820	
Compatibility Identifier	55000-820	
Type	Switch Monitor Input/Output Module	
Style	Fascia plate with wiring terminals	
Dimensions	4½" x 4½" x 1"	
Temperature Range	32°F to 120°F (0°C to 49°C)	
Humidity	10 to 93% RH Non-condensing	
Wiring Size	24AWG - 14AWG	
Signal Line Circuit (SLC)	Supervised Power Limited	
Working Voltage	17-28V dc	
Operating Current	Modulation Voltage	5-9V (peak to peak)
	Supervisory Current	2.5mA
	Surge Current	7.5mA
	Maximum Alarm Current	6.0mA (LED on)
Functional States	Analog Level (Normal)	16
	Analog Level (Alarm)	64
	Analog Level (Trouble)	4
Initiating Device Circuit (IDC)		
Wiring styles	Supervised power limited Class A and Class B	
	Voltage	10V dc
	Current	1.7mA max
	Line impedance	100Ω max
End-of-Line Resistors	47KΩ (A UL listed end-of-line resistor is available from Apollo and can be ordered under part number 44251-146).	
Open Collector Input	Not supervised Logic 1 is > 4V dc Logic 0 is < 1V dc	
Relay Output	Non supervised, programmable, dry contact 24V dc, 1A:30V ac, 0.5A (resistive)	

Functional Test Data

Output Bit	Function	Input Bit	Function
2	Alarm LED 1 = On 0 = Off	2	Alarm LED Confirmation 1 = On 0 = Off
1	Not Used	1	Indicates Class Wiring 1 = Class B* 0 = Class A
0	Relay Control 1 = On 0 = Off	0	Opto-isolated Input Status 1 = Input low 0 = Input high

* Note: Toggles to '0' in alarm.

©Apollo Fire Detectors Ltd 2017

Apollo Fire Detectors Ltd, 36 Brookside Road, Havant, Hants, PO9 1JR, UK
Tel +44 (0)23 9249 2412 Fax +44 (0)23 9249 2754
Email: techsales@apollo-fire.com Website: www.apollo-fire.co.uk

In the USA: Apollo America Inc., 25 Corporate Drive, Auburn Hills, Michigan, 48326, USA
Tel: (248) 332-3900 Fax: (248) 692-0888
Email: info.us@apollo-fire.com Website: www.apollo-fire.com



XP95A Switch Monitor Input/Output Module Installation Instructions

General

The XP95A Switch Monitor Input/Output Module, part no 55000-820, is a loop-powered device which incorporates a monitored input circuit for connection to remote switches. It also has an unmonitored opto-coupled input and volt-free relay output. It is mounted on a plastic fascia plate for use with a 4" square or 2 gang electrical backbox (minimum depth 2¼").

A red LED flashes in synchronization with the current pulse reply from the device. If output bit 2 is set, the LED is illuminated continuously.

Note: the XP95A Switch Monitor Input/Output Module is designed for indoor use only.

Control Panel Compatibility

The module has been listed by Underwriters Laboratories Inc. For details of compatible control panels contact Apollo Fire Detectors Limited. Please check fire control panel literature for compatible Apollo devices.

Installation

These products must be installed in accordance with the applicable NFPA standards, local codes and jurisdictional authorities. Failure to follow these instructions may result in failure of devices to report an alarm condition. Apollo Fire Detectors Limited is not responsible for devices which are improperly installed, maintained and tested.

Before installing these products, check the continuity, polarity and insulation resistance of all wiring. Check that siting is in accordance with the fire system drawings and conforms to all applicable local codes such as NFPA 72.

1. Mount the electrical box as required and install all cables for termination. Where applicable ensure that cable shield/earth continuity is maintained.
2. Drill holes in the fascia plate corresponding to the holes on the mounting box selected (Fig. 1).
3. Terminate all cables in compliance with local codes and regulations.
4. Set the address of the module as shown on page 3.
5. Gently push the completed assembly towards the mounting box and align the fixing holes. Secure the unit with the screws provided. **Do not overtighten the screws.**
6. Commission the module.

Relay Functionality

The relay is operated by setting output bit 0. If the supply voltage is removed, the relay will not change state. When the Switch Monitor Input/Output Module is powered up, the relay will be in the same state as it was prior to the module being switched off but the module will respond to output bit 0 four seconds after power has been applied. If the module has not been interrogated, a relay reset will automatically be applied.

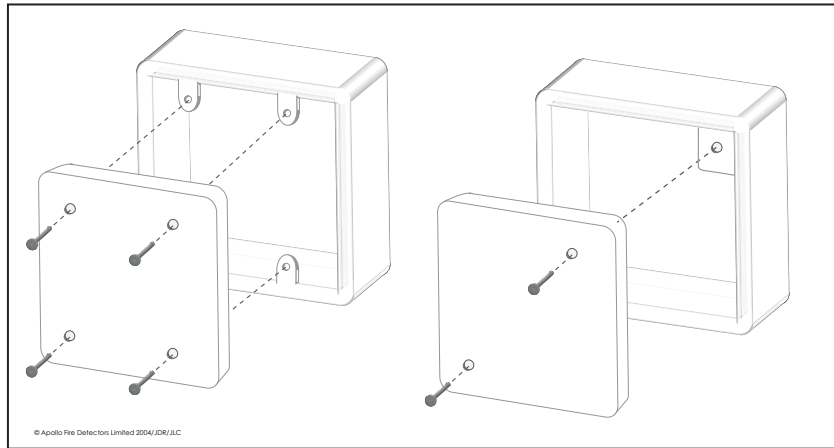

Fig. 1- Mounting the XP95A Switch Monitor Input/Output Module

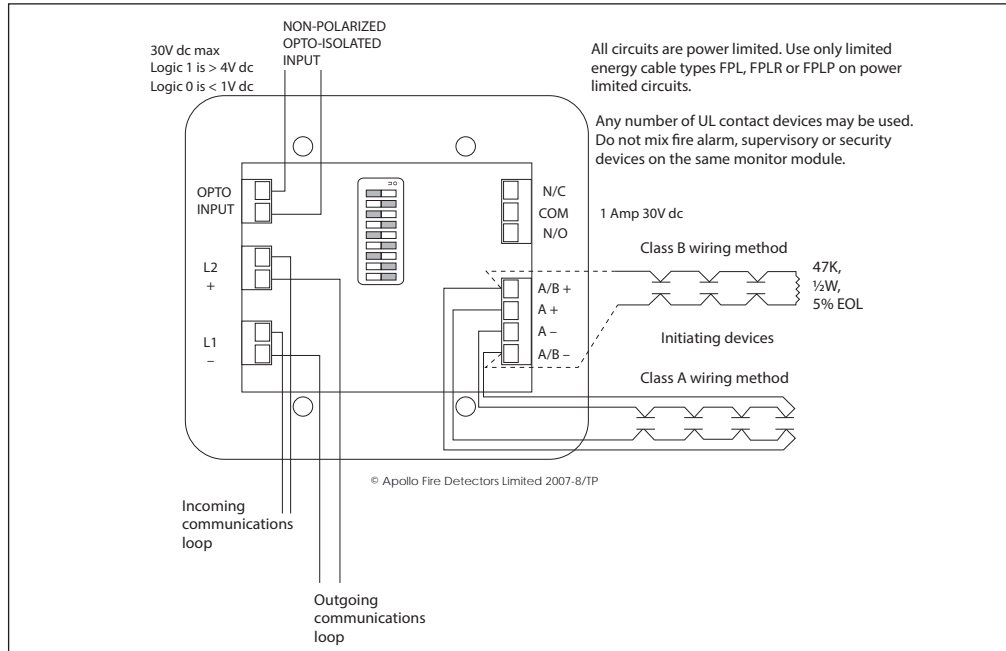

Fig. 2- Wiring Diagram for XP95A Switch Monitor Input/Output Module

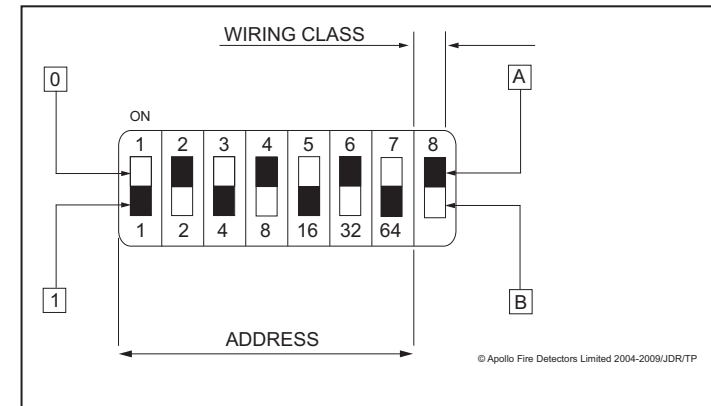

Fig. 3- DIL Switch

Address Setting

Segments 1-7 of the DIL Switch are used to select the address of the module. Each of the seven segments must be set to '0' (ON) or '1' (OFF) using a small screwdriver or similar tool. A complete list of address settings is shown below (The eighth segment of the switch is used to select Class A or B wiring).

addr	DIL switch setting 1234567	addr	DIL switch setting 1234567	addr	DIL switch setting 1234567	addr	DIL switch setting 1234567	addr	DIL switch setting 1234567
1	1000000	11	1101000	21	1010100	31	1111100	41	1001010
2	0100000	12	0011000	22	0110100	32	0000010	42	0101010
3	1100000	13	1011000	23	1110100	33	1000010	43	1101010
4	0010000	14	0111000	24	0001100	34	0100010	44	0011010
5	1010000	15	1111000	25	1001100	35	1100010	45	1011010
6	0110000	16	0000100	26	0101100	36	0010010	46	0111010
7	1110000	17	1000100	27	1101100	37	1010010	47	1111010
8	0001000	18	0100100	28	0011100	38	0011010	48	0000110
9	1001000	19	1100100	29	1011100	39	1110010	49	1000110
10	0101000	20	0010100	30	0111100	40	0001010	50	0100110
51	1100110	61	1011110	71	1110001	81	1000101	91	1101101
52	0010110	62	0111110	72	0001001	82	0100101	92	0011101
53	1010110	63	1111110	73	1001001	83	1100101	93	1011101
54	0110110	64	0000001	74	0101001	84	0010101	94	0111101
55	1110110	65	1000001	75	1101001	85	1010101	95	1111101
56	0001110	66	0100001	76	0011001	86	0110101	96	0000011
57	1001110	67	1100001	77	1011001	87	1110101	97	1000011
58	0101110	68	0010001	78	0111001	88	0001101	98	0100011
59	1101110	69	1010001	79	1111001	89	1001101	99	1100011
60	0011110	70	0110001	80	0000101	90	0101101	100	0010011
101	1010011	111	1111011	121	1001111				
102	0110011	112	0000111	122	0101111				
103	1110011	113	1000111	123	1101111				
104	0001011	114	0100111	124	0011111				
105	1001011	115	1100111	125	1011111				
106	0101011	116	0010111	126	0111111				
107	1101011	117	1010111						
108	0011011	118	0110111						
109	1011011	119	1110111						
110	0111011	120	0001111						