



DIN-Rail Mains Input/Output Unit Installation Guide



General

The DIN-Rail Mains Input/Output Unit, part no 55000-797, is a loop-powered device which provides a single-pole voltage-free changeover relay output and a monitored input. The unit is designed to be mounted in a suitable enclosure, clipped onto a 35mm DIN-Rail.

To ensure compliance to EN54-18 is maintained, this device shall be installed within an enclosure weighing greater than 4.75 kg.

If voltages greater than 50V are connected to the relay contacts of the unit (pins 10, 11 and 12) it is the responsibility of the installer that the unit and connections comply with the Low Voltage Directive.



The standard applicable for safety aspects is:
BS EN 60950:2006 'Safety of information technology equipment'.

Important notes:

1. Installation must be carried out by a suitably qualified person. Instructions for connected equipment must be carefully observed. If this is not done the protection afforded by the equipment may be impaired.
2. The connected control panel must comply with IEC/BS EN 60950 for safety or applicable local codes.
3. The DIN-Rail Mains Input/Output Unit has accessible live terminals and must be housed in a protective enclosure to prevent access to these terminals by an operator. The enclosure must be capable of ensuring an environment with no condensation.
4. Circuits connected to the relay contacts on pins 10, 11 and 12 must be protected by a fuse or circuit breaker to ensure that the relay contact rating is not exceeded in normal or in a fault condition. The protection device must have adequate breaking capacity to interrupt the maximum fault current that can flow.
5. Mains voltage wiring and connectors must be correctly insulated to ensure isolation from low voltage circuits. The mains input/output provides isolation internally between the relay contacts and the other circuits connected to the unit.
6. Mains connectors and wiring must be mechanically anchored that in the case of breakage or unit removal for maintenance there can be no accidental contact with other wiring circuits.

© Apollo Fire Detectors Limited 2012

Apollo Fire Detectors Limited,
36 Brookside Road, Havant, Hants, PO9 1JR, UK
Tel +44 (0) 23 9249 2412 Fax +44 (0) 23 9249 2754
Email: techsales@apollo-fire.co.uk Website: www.apollo-fire.co.uk

- Mains voltage circuits should be marked so that correct connection is obvious in the case of unit removal during maintenance. Both the plug-in connector and the socket are marked as "pins 10, 11 & 12".

Installation

- Run the cables from the loop, the monitored input circuit and the relay connections observing the safety requirements on page 1.
- When screened loop cables are used (for functional screening only - this is not a safety earth) connect the screen in accordance with the instructions of the control panel manufacturers. Always ensure that all segments of the loop cable have continuity of the functional earth and take care that it is insulated from any other earth point such as metalwork, cable trays or junction boxes.
- Set the unit address on segments 1–7 of the DIL switch in accordance with the address table on page 3.

If the LEDs are to be disabled, set segment 8 of the DIL switch to ON.

- Remove the backing strip from the lower portion of the label.
- Fix the lower portion of the label firmly to the unit, ensuring the DIL switch access hole is covered.
- Clip the unit to the standard 35mm DIN-Rail (DIN 46277)
Please use end stops, part number 27447-528 or equivalent, at each end of the unit to secure it in place

Wiring Details

All wiring terminals will accept solid or stranded cables up to 2.5mm²

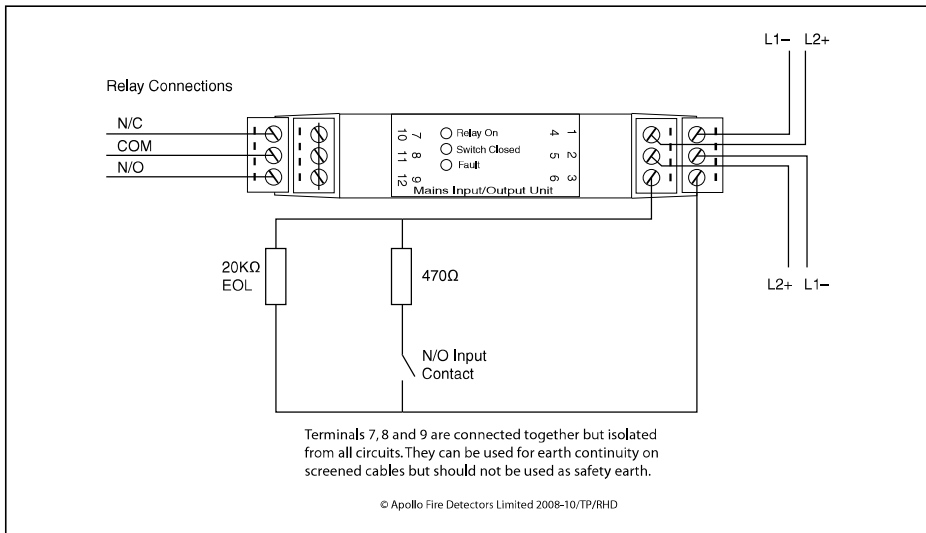

Fig 1 Connecting diagram for Input/Output Unit

Input conditions and status

Resistance across Input	Status	Analogue value	Input Bits 2 1 0
<100Ω	Short-circuit fault	4	0 0 0
100-200Ω	Indeterminate	4 or 16	0 0 0 or 1
200-11KΩ 470Ω*	Switch closed	16	0 0 1
11-15KΩ	Indeterminate	16	0 0 0 or 1
15-25KΩ 20KΩ*	Normal (switch open)	16	0 0 0
25-30KΩ	Indeterminate	4 or 16	0 0 0
>30KΩ	Open-circuit fault	4	0 0 0

*The values in *italics* are recommended values.

Troubleshooting

Before investigating individual units for faults, it is very important to check that the system wiring is fault-free. Earth faults on a data loop or any ancillary zone wiring may cause communication errors. Many fault conditions are the result of simple wiring errors. Check all connections to the unit and make sure that the correct value resistors are fitted where necessary.

Fault Finding

Problem	Possible Cause
No response or missing	Incorrect address setting Incorrect loop wiring
Fault condition reported	Incorrect input wiring Incorrect end-of-line resistor fitted
Relay fails to operate	Incorrect wiring Control panel has incorrect cause and effect programming
Analogue value unstable	Dual address Loop data fault, data corruption

Address Setting

The address of the Input/Output Unit is set using the lower seven segments of the DIL switch. Each segment of the switch must be set to "0" or "1", using a small screwdriver or similar tool.

A complete list of address settings is shown below.

addr	DIL switch setting 1234567	addr	DIL switch setting 1234567	addr	DIL switch setting 1234567	addr	DIL switch setting 1234567	addr	DIL switch setting 1234567
1	1000000	11	1101000	21	1010100	31	1111100	41	1001010
2	0100000	12	0011000	22	0110100	32	0000010	42	0101010
3	1100000	13	1011000	23	1110100	33	1000010	43	1101010
4	0010000	14	0111000	24	0001100	34	0100010	44	0011010
5	1010000	15	1111000	25	1001100	35	1100010	45	1011010
6	0110000	16	0000100	26	0101100	36	0010010	46	0111010
7	1110000	17	1000100	27	1101100	37	1010010	47	1111010
8	0001000	18	0100100	28	0011100	38	0110010	48	0000110
9	1001000	19	1100100	29	1011100	39	1110010	49	1000110
10	0101000	20	0010100	30	0111100	40	0001010	50	0100110
51	1100110	61	1011110	71	1110001	81	1000101	91	1101101
52	0010110	62	0111110	72	0001001	82	0100101	92	0011101
53	1010110	63	1111110	73	1001001	83	1100101	93	1011101
54	0110110	64	0000001	74	0101001	84	0010101	94	0111101
55	1110110	65	1000001	75	1101001	85	1010101	95	1111101
56	0001110	66	0100001	76	0011001	86	0110101	96	0000011
57	1001110	67	1100001	77	1011001	87	1110101	97	1000011
58	0101110	68	0010001	78	0111001	88	0001101	98	0100011
59	1101110	69	1010001	79	1111001	89	1001101	99	1100011
60	0011110	70	0110001	80	0000101	90	0101101	100	0010011
101	1010011	111	1111011	121	1001111				
102	0110011	112	0000111	122	0101111				
103	1110011	113	1000111	123	1101111				
104	0001011	114	0100111	124	0011111				
105	1001011	115	1100111	125	1011111				
106	0101011	116	0010111	126	0111111				
107	1101011	117	1010111						
108	0011011	118	0110111						
109	1011011	119	1110111						
110	0111011	120	0001111						

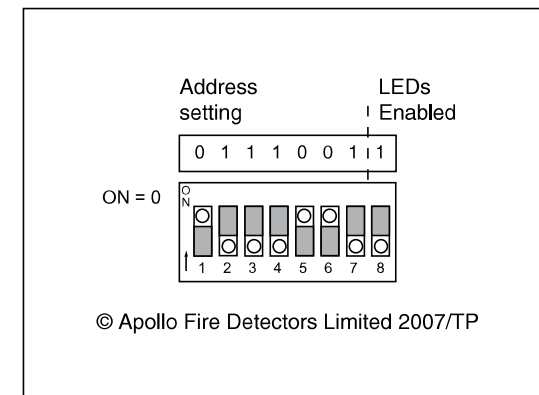

Fig 2 Example of DIL switch setting using address 78

Commissioning

The relay state is set by protocol messages from the CIE by way of the loop positive and negative lines. It should be noted that when first powered up the relay state will be mechanically latched into the state it was when the unit was last powered.

When powered up there is a 30 second delay during which the state does not change but the CIE can send a message for the required state. At the end of the delay this state is taken up by the relay. If no message is sent, the relay will automatically return to the 'normal' state (open circuit between common and normally open). If required the relay can be reset by applying 24 volts from a power supply for 30 seconds.

It is important that the DIN-Rail Input/Output Unit be fully tested after installation. A Test Set, part no 55000-870, may be used to carry out functional testing of individual units. It can also be used to perform data integrity tests of an entire loop.

LED Indicators

⊙	Relay On	Illuminated red when relay is in the SET state*
⊙	Switch Closed	Illuminated red when monitored field contact is closed
⊙	Fault	Illuminated yellow when input is open or short circuit

* The relay state is not monitored. The switch input is intended to be used to monitor a set of dry contacts that confirm operation of the equipment being controlled.

To conserve loop current the LEDs can be disabled by setting the 'LED ENABLE' segment of the DIL switch to '0'.

Functional Test Data

output bit	function	input bit	function
2	not used	2	not used
1	not used	1	not used
0	operates relay 1 = 'SET' 0 = 'NORMAL'	0	monitored input 0 = contact open 1 = contact closed

Technical data

Loop voltage	17–28V DC
Maximum current consumption at 28V (no protocol)	
LED Enabled	
switch-on surge 150ms	6mA
quiescent, 20kΩ EOL fitted	1.5mA
switch input closed, LED on	5.5mA
any other condition, max 2 LEDs on	5mA
LED Disabled	
switch-on surge 150ms	6mA
quiescent, 20kΩ EOL fitted	1.5mA
switch input closed	2.5mA
any other condition	2.5mA
Rated load at 65°C ambient	5A at 250V AC (resistive) 2A at 48V DC (resistive)
Rated load at 55°C ambient	8A at 250V AC (resistive)
Max switching capacity at 250V 50Hz	2kVA
Switch input monitoring voltage (open-circuit condition)	9–11V DC
Maximum cable resistance	50Ω
Environmental Data - See Note A	
Operating temperature	–20°C to +65°C
Humidity (no condensation)	0–95%RH
Cyclic humidity	} to GEI 1–052
Impact	
Surface temperature under maximum load	} EN54-18:2005
Vibration	
Rigidity	
Dielectric strength	
IP rating	20
Radiated emissions	BS EN 61000-6: 2007
Radiated immunity	BS EN 50130–4: 1996
Isolation between relay contacts and other circuits	tested to 2.2KV



Complies with EMC Directive 2014/30/EU

Note A - The operating ambient temperature is that at the outer surface of the Mains I/O case. Consideration should be made of the temperature rise within the protective enclosure which may contain other sources of heat - depending on the installation.